



# TRIZ Ltd



MZ Construction Consumable Supplies LTD

## (Engineering Problems Realization Company)



MZ Construction Consumable Supply LTD

10 North Avenue, Hayes,  
Middlesex, United Kingdom,  
UB3 2JE

Contact Number:

+442080610941

+447424438725

<https://youtu.be/sXykUAQAEJc>

Contact Email: [mz@mzccs.co.uk](mailto:mz@mzccs.co.uk)

Web site: [www.mzccs.co.uk](http://www.mzccs.co.uk)



**MZ Construction Consumable Supplies LTD**

10 North Avenue, Hayes,  
Middlesex, United Kingdom,  
UB3 2JE

Contact Number,  
+442080610941  
+447424438725

Contact Email: [mz@mzccs.co.uk](mailto:mz@mzccs.co.uk)  
**Web site:** [www.mzccs.co.uk](http://www.mzccs.co.uk)

TRIZ LLC

We pleasure to well come in our family as united Kingdom partners **M/S MZ Construction Consumable Supply LTD ( MZCCS )** appointed Middle East market.

#### **Introduction TRIZ (www.triz-ltd.com)**

A modern production and engineering company established in 1990. We carry out a full cycle of work - design, including gas-dynamic and strength calculations, manufacturing, installation, commissioning, service maintenance, diagnostics, repair, modernization of dynamic equipment for chemical, petrochemical, gas transportation, oil production and other industries.

ALL PRODUCTS ARE DESIGNED AND MANUFACTURED IN ACCORDANCE WITH API STANDARDS

**(Certificates No. ODC1820-0749/1 and No. 2000266/1).**

Modern design solutions are protected by patents (more than two hundred in total), which ensures high reliability - continuous operation of units without back up or shutdowns for at least three years.

One of the main specializations of TRIZ is solving problematic issues in the operation of dynamic equipment (increased vibration, axial displacement, instability of operational characteristics, etc.)

#### **Main products of TRIZ:**

custom-made centrifugal compressors (including for gas pumping units) and replaceable flow parts for them;  
pumps for special purposes on order;  
damper plain bearings and thrust bearings with high load-bearing capacity;  
elastic couplings; rotors, impellers, high-performance seals and other spare parts for dynamic equipment;  
spare parts for piston compressors  
production of other spare parts and products according to the Customer's drawings.

#### **Main TRIZ services:**

design and modernization of centrifugal compressors in order to increase productivity, reliability, residual life;  
design and modernization of piston compressors for the purpose of switching to operation without lubrication or in limited lubrication mode;  
installation and commissioning, repair and maintenance of dynamic equipment;

diagnostics and production of spare parts for compressors, turbines, turboexpanders, pumps, multipliers, gearboxes according to existing drawings or based on reengineering;  
metalworking according to the Customer's drawings.

Over more than **thirty years of research and production activity**, we have developed a number of original units, the implementation of which, at low costs, allows us to increase the productivity and efficiency of dynamic equipment, reduce the cost of its operation, which accordingly increases the economic profitability of production in general.

**Since TRIZ** units have a proven effectiveness of their use on compressors and turbines for ground use, multiple positive references, we offer them for consideration for use both on new equipment and on existing equipment as its modernization.

**TRIZ products and services are most applicable to the following segments:**

manufacturers of compressor equipment with high reliability requirements  
(development and production of compressors, replaceable flow parts, rotors, etc.);  
petrochemical enterprises in order to increase the efficiency and reliability of operation of dynamic equipment through the use of highly efficient sealing, bearing and other units; energy industry  
(custom-designed TRIZ bearing supports are used as part of **GE Power projects** for modernizing turbines);  
we are ready to act as a subcontractor in the development and manufacture of gas compressor units; there are interesting engineering developments in this direction;  
are interested in the possibility of creating a joint venture for the purpose of joint production of spare parts, carrying out inspections, repairs, and service.

**The Reference list**

Contains several hundred successfully and efficiently completed projects for the manufacture of new equipment and repair/modernization of existing dynamic machines at the facilities of such companies as JSC Acron, JSC OSTHEM, PJSC "Ukrnafta", PJSC "DneprAzot", JSC FerganaAzot, NPO Iskra, PJSC Turbogaz, ALSTOM, Siemens, GE and many others.

**Until Year 2022**, we were certified suppliers of many key companies producing ammonia and urea: JSC MCC Euro-Chem, Russia; JSC UCC Uralchem, Russia; JSC "Grodno Azot", Republic of Belarus; "OSTCHEM", Ukraine; PJSC Acron, Russia; KAO "AZOT", Russia; AT "OPZ", Ukraine; PJSC "Concern Stirol", Ukraine; PJSC "Severodonetsk Azot Association", Ukraine; PJSC "Severodonetsk Azot Association", Ukraine; JSC "Farg'onaaazot", Uzbekistan; JSC "Maksam-Chirchik", Uzbekistan and many more.

The **guaranteed** service life of the supplied units meets the requirement of continuous 2-6 years of operation.

The presence of highly qualified specialists, modern production, our own unique developments and engineering solutions allow us to solve complex problems in the design and manufacture of individual new equipment, as well as the manufacture of spare parts and modernization of equipment from such manufacturers as GE, Nuovo Pignone, Siemens, Demag Delaval, Atlas Copco, Dresser-Rand, Flowserve, Piller, MHI, CKD, Howden, Crousot-Loire, Hitachi, Sumy NPO, Kazankompressormash and other companies.

We are confident that our technical potential will make a significant contribution to improving the quality and efficiency of dynamic equipment in various industries, reducing the costs of its operation and thus increasing the profitability and competitiveness of enterprises. Together for the better!

## Information about the company

TRIZ LLC was founded in 1990 in Sumy, Ukraine. Currently, the group of companies "TRIZ" includes a number of Ukrainian enterprises and the Latvian trading house "TRIZ TRADE".

TRIZ supplies a wide range of in-house products and services for the chemical, petrochemical, gas transportation, oil-producing, energy and other industries.

TRIZ is one of the leading companies in the machine-building industry with a full production cycle **from design to service and specializes in the production of compressors, pumps and auxiliary equipment. The company also provides services for the repair, reconstruction, increase of reliability, efficiency, dynamic stability, resource, service life of dynamic equipment of various manufacturers.**

Intellectual and production capabilities of "TRIZ" allow to implement projects for the **reconstruction and modernization** of equipment without the involvement of contractors, which makes it possible to conduct continuous monitoring of all production processes.

"TRIZ" systematically expands **production facilities**, equipping them with modern equipment, in order to fully and timely meet the requirements of our customers.

TRIZ has an extensive reference of supplies and services for the largest companies in Ukraine, Russia, Belarus, Uzbekistan, Poland and other countries in Europe and Asia.

Nowadays there are more than 150 names of centrifugal equipment which has been modernized according to the "TRIZ" Ltd technology and are successfully operated.

**All products of the company are manufactured in accordance with the requirements and recommendations of API standards (certificates No. ODC1820-0749 / 1 and No. 2000266/1).**



Contact details:  
+442080610941 +447424438725  
Contact Email: [mz@mzccs.co.uk](mailto:mz@mzccs.co.uk) Web site: [www.mzccs.co.uk](http://www.mzccs.co.uk)

[www.triz-ltd.com](http://www.triz-ltd.com)

Together we are the best!

## Basic services

- ✓ Modernization of compressor and pumping equipment;
- ✓ *Mounting and repair of the rotating equipment;*
- ✓ Vibrodiagnostic inspection of rotor machines;
- ✓ *Axial stability increase of the rotating equipment;*
- ✓ Rotors balancing;
- ✓ *Rotors repair;*
- ✓ Strain-free machine parts reconstruction;
- ✓ *Energy saving technologies adoption;*
- ✓ Supply of spare parts.

The developments of the enterprise have trade mark and patent-protected, have modern scientific level and have been examined practically, that allows to take dominant position in compressor and pump reliability improvement.



Contact details:  
+442080610941 +447424438725  
Contact Email: [mz@mzccs.co.uk](mailto:mz@mzccs.co.uk) Web site: [www.mzccs.co.uk](http://www.mzccs.co.uk)

[www.triz-ltd.com](http://www.triz-ltd.com)

Together we are the best!

# Main products



Rotors and replacement flow parts



Flexible couplings



Damping journal bearings



Thrust bearings



Radial seals

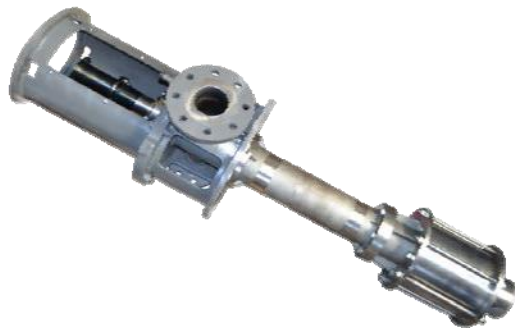

Special-purpose pumps

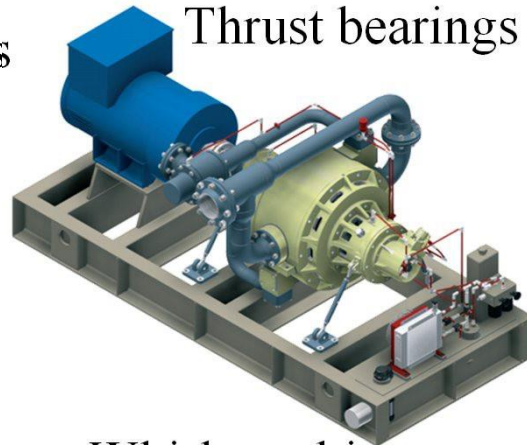

Whirl machines

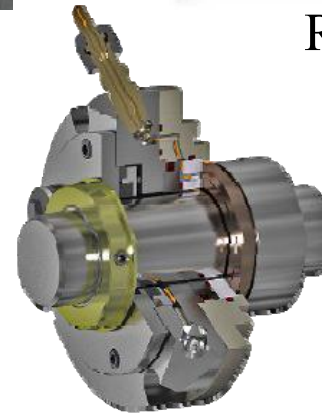

Shaft-end seals



Impellers



Contact details:  
+442080610941 +447424438725  
Contact Email: [mz@mzccs.co.uk](mailto:mz@mzccs.co.uk) Web site: [www.mzccs.co.uk](http://www.mzccs.co.uk)

[www.triz-ltd.com](http://www.triz-ltd.com)

Together we are the best!

# Centrifugal compressors

Centrifugal compressors are custom-made. Design documentation is developed in accordance with the terms of reference agreed with the Customer. The term of design and manufacture is about two years.

**Centrifugal compressors are designed in accordance with the requirements of standard API 617 (Certificate No. ODC1820-0749 / 1).**

## Advantages:

The main advantage of compressors manufactured by TRIZ is high reliability and efficiency, stable operation of the unit in a wide range of operating modes, consistently low losses throughout the turnaround cycle, low vibration, high maintainability.

The design of impellers uses the most modern methods of profiling blades to achieve maximum efficiency. Manufacturing is carried out on high-precision equipment. Corrosion-resistant steels are used to ensure durability in aggressive environments.



Contact details:  
+442080610941 +447424438725  
Contact Email: [mz@mzccs.co.uk](mailto:mz@mzccs.co.uk) Web site: [www.mzccs.co.uk](http://www.mzccs.co.uk)

[www.triz-ltd.com](http://www.triz-ltd.com)

Together we are the best!

# Centrifugal compressors

All compressors are equipped with damper bearings and seals of the original patented design. This allows minimizing of reactive forces on the rotor and guaranteeing its dynamic stability in all operating modes, including the most loaded starting and transient modes. Axial stability of the rotor is guaranteed including thrust bearings with high bearing capacity.

Flexible couplings used in TRIZ compressors ensure reliable torque transfer, relieving the rotor system from the reactive forces and compensating installation and operating deviations of the rotors. Carefully selected modern materials, high-precision machining of parts on modern machining centers, multi-level control of production processes allows the manufacture of compressors at the level of world standards.

"TRIZ" performs the full cycle of works for the supply of compressor units, including the development and coordination of technical specifications, gas-dynamic and strength calculations, design, manufacture, installation, testing of the unit under operating conditions.



MZ Construction Consumable Supplies LTD

Contact details:  
+442080610941 +447424438725  
Contact Email: [mz@mzccs.co.uk](mailto:mz@mzccs.co.uk) Web site: [www.mzccs.co.uk](http://www.mzccs.co.uk)

[www.triz-ltd.com](http://www.triz-ltd.com)

Together we are the best!



# The main characteristics of centrifugal compressors “TRIZ”

Rated power	Up to 32 MW
Minimum suction pressure	0,3 kgf / cm <sup>2</sup>
Maximum discharge pressure	1000 kgf / cm <sup>2</sup>
Input flow range	From 21,0 to 800 m <sup>3</sup> / min
Rotations speed	Up to 24000 rpm
Number of compression stages	Up to 10 in section
Drive type	Electric motor, turbine, combined etc.
Working environment	Natural gas, methane, nitrogen-hydrogen medium, carbon dioxide, air, ammonia, hydrogen, nitrogen, etc.
Low vibration	Less than 15 microns
High precision and quality of manufacturing components on the latest production equipment	

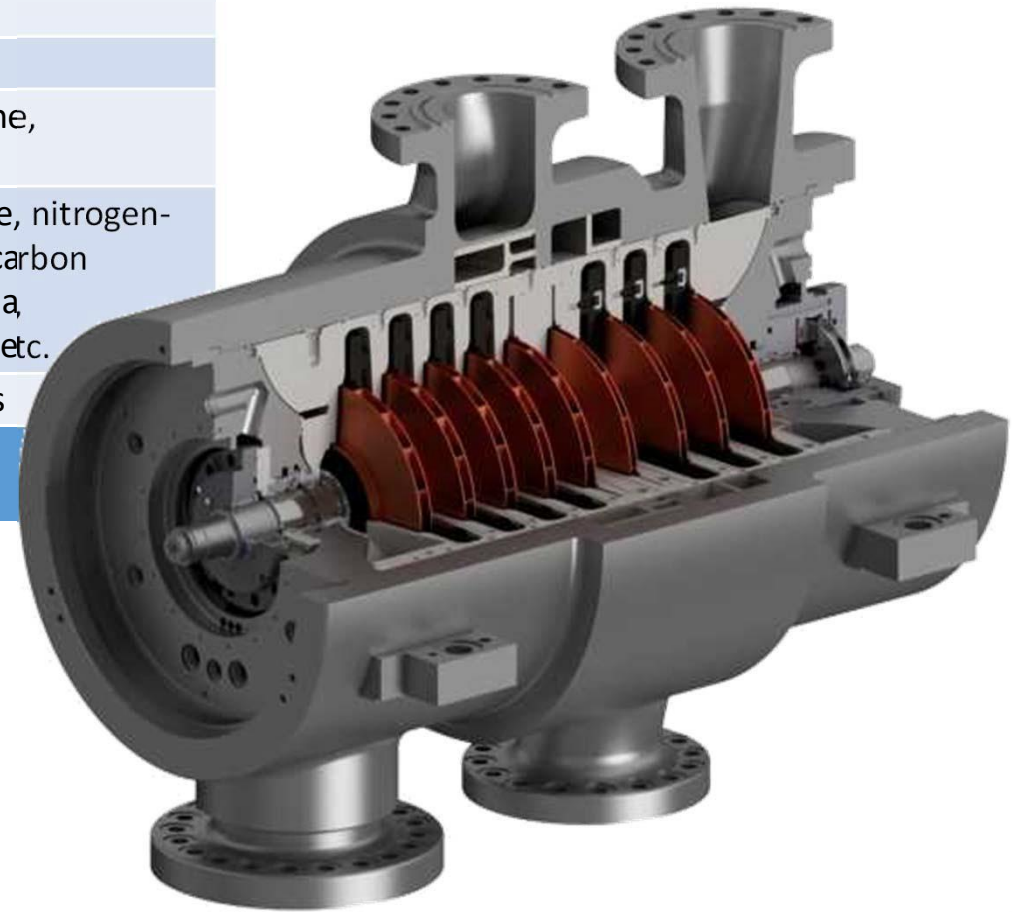

Contact details:  
+442080610941 +447424438725  
Contact Email: [mz@mzccs.co.uk](mailto:mz@mzccs.co.uk) Web site: [www.mzccs.co.uk](http://www.mzccs.co.uk)

[www.triz-ltd.com](http://www.triz-ltd.com)

Together we are the best!

# Modernization of centrifugal compressors

A comprehensive upgrade is performed by replacing the replaceable flow path (inner case and rotor) and is used to match the operating characteristics of the compressor with the operating conditions when they change, for example:

- linear compressor stations of main gas pipelines in order to optimize operating modes;
- booster compressor stations to ensure stable gas production under conditions of intense pressure drop in the final stages of field development;
- oil fields in gas-lift oil production;
- at underground gas storage stations for the rational use of equipment in the face of changing gas injection pumping modes;
- chemical industry enterprises (ammonia, carbamide production, urea production, etc.);
- refineries.



Contact details:  
+442080610941 +447424438725  
Contact Email: [mz@mzccs.co.uk](mailto:mz@mzccs.co.uk) Web site: [www.mzccs.co.uk](http://www.mzccs.co.uk)

[www.triz-ltd.com](http://www.triz-ltd.com)

Together we are the best!

## Modernization is also the optimal solution in the following cases:

- replacement of morally obsolete nodes with a low resource of work with modern design nodes in order to increase the reliability of the unit
- matching compressor performance with actual or desired performance;
- reconstruction of damaged compressors;
- increase the dynamic stability of the rotor;
- prevention of axial rotor shift;
- extension of service life;
- elimination of other frequently repeated problems in the operation of the units.



**TRIZ performs a full cycle of modernization work, including a comprehensive inspection of the unit under operating conditions, the development and approval of technical specifications, gas-dynamic and strength calculations, design, manufacture, installation, testing of an upgraded unit under operating conditions.**

### Advantages:

- high reliability of centrifugal compressors;
- efficiency is 2 ... 4% higher compared to competing solutions due to the use of reliability nodes;
- low vibration;
- stability of characteristics during the period between repairs;
- long operational resource;
- technical solutions of TRIZ have been repeatedly tested, are used in non-redundant compressor units with a turnaround time of at least three years.



Contact details:  
+442080610941 +447424438725  
Contact Email: [mz@mzccs.co.uk](mailto:mz@mzccs.co.uk) Web site: [www.mzccs.co.uk](http://www.mzccs.co.uk)

[www.triz-ltd.com](http://www.triz-ltd.com)

Together we are the best!

# Rotors and flow parts of centrifugal compressors

Currently, TRIZ designs and manufactures rotors and flow parts to compressors and centrifugal machines operating in the chemical and oil and gas industry in accordance with the requirements of API 617 (Certificate No. ODC1820-0749 / 1).

The wide experience of work and an individual approach to each problem of the customer favorably distinguishes TRIZ among competitors.

The production and technical capabilities of TRIZ allow the manufacture of compressors, rotors for the main positions of the chemical, gas, petrochemical and other industries.

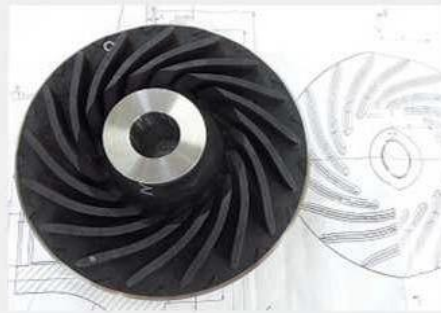
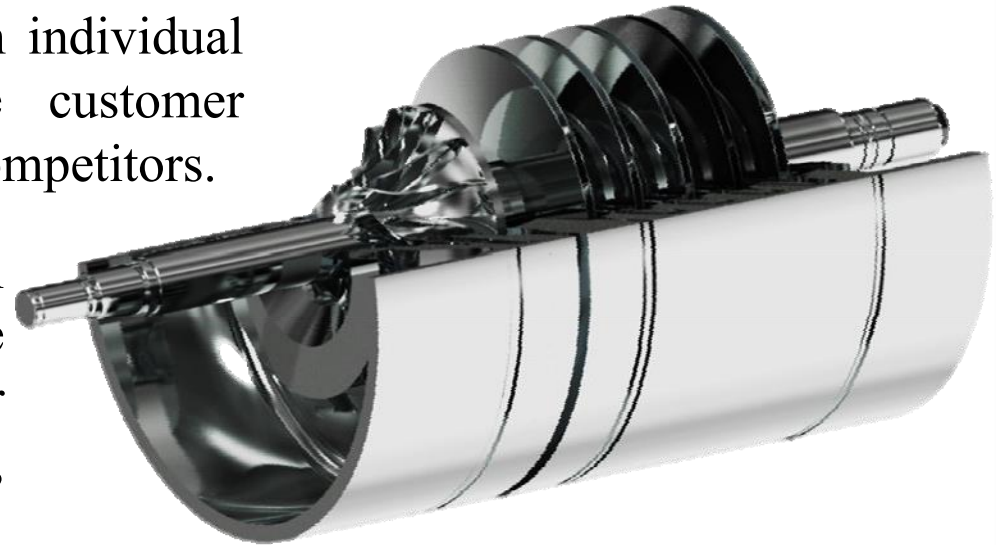

Contact details:  
+442080610941 +447424438725  
Contact Email: miz@mzccs.co.uk Web site: www.mzccs.co.uk

[www.triz-ltd.com](http://www.triz-ltd.com)

Together we are the best!

## Rotors of centrifugal compressor units

While projecting the rotor impellers and their flow parts the modern methods of gas dynamic analysis are used, including blades profiling that allows reaching the maximum compressor efficiency.

Strength calculations allow detecting the trouble spots of the construction at the stage of projecting.

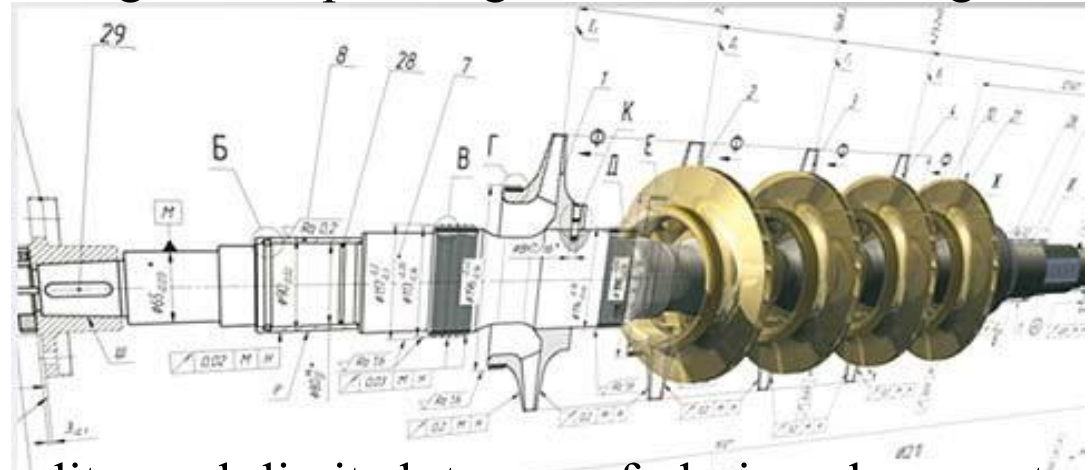

3D projecting provides high quality and limited terms of design documents preparation. The models are the basis for gas dynamic, strength analyses fulfillment and development of control software for NC machine tools.

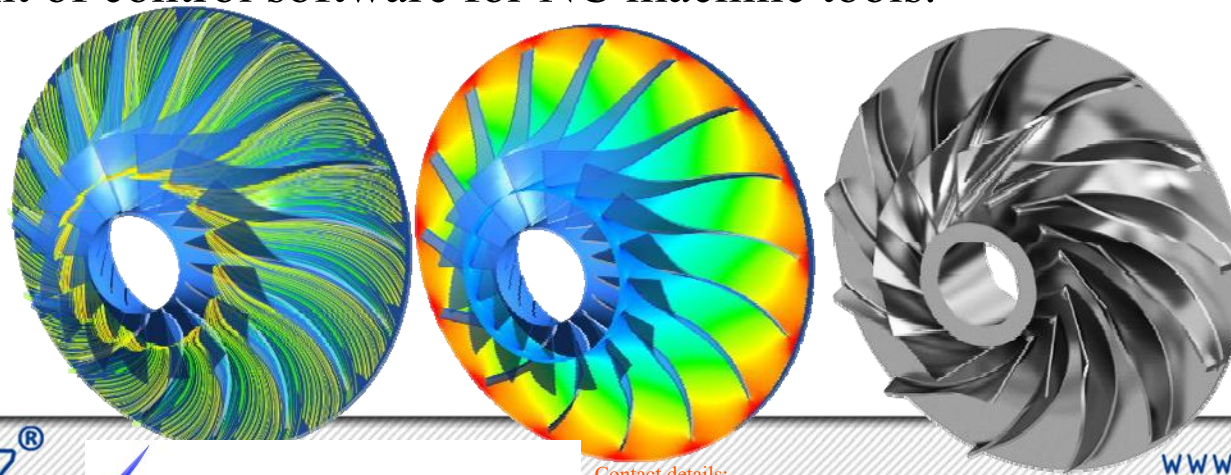

Contact details:  
+442080610941 +447424438725  
Contact Email: [mz@mzccs.co.uk](mailto:mz@mzccs.co.uk) Web site: [www.mzccs.co.uk](http://www.mzccs.co.uk)

[www.triz-ltd.com](http://www.triz-ltd.com)

Together we are the best!

## Advantages of TRIZ rotors

- when designing impellers, modern methods of blades profiling are used, which allow to achieve maximum efficiency;
- at the design stage, all critical parts are subject to strength calculations;
- the use of high-quality corrosion-resistant steels for manufacture of impellers ensures their durability in aggressive environments and increases the service life of the unit;
- milling of impeller blades is performed on modern five- and four-axis machine tools with numerical control, making it possible to process parts with complex spatial geometry, high dimensional accuracy and surface quality;
- technology of welding of impellers “into groove” in the environment of protective gases allows to perform high-strength, corrosion-resistant welded joints, allowing to increase the turnaround time compared to riveted joints by 7-10 times. Welding is carried out by highly qualified personnel who have appropriate approvals and permits for such work;
- the whole cycle of parts processing is carried out in one enterprise, which allows to carry out quality control over the manufacture of parts;
- the production base allows machining of shafts up to 3800 mm long. The maximum diameter of spatial impellers is up to 860 mm, and those with cylindrical blades are up to 2000 mm.



Contact details:  
+442080610941 +447424438725  
Contact Email: [mz@mzecs.co.uk](mailto:mz@mzecs.co.uk) Web site: [www.mzecs.co.uk](http://www.mzecs.co.uk)

[www.triz-ltd.com](http://www.triz-ltd.com)

Together we are the best!



## **DAMPING JOURNAL BEARINGS – PD**

Since 1990 bearings TRIZ® have been used for replacement of the regular bearings of centrifugal compressors, pumps, steam and gas turbines, electric motors, generators, multipliers, gears and other equipment in order to decrease rotor vibrations and to increase equipment reliability. They have been used in a new machinery manufacturing.

Journal bearings are the most important assemblies, providing the rotor spinning stability of the modern high-speed units: turbo-compressors, gas turbines, turborefrigeration machines, high-speed multipliers, pumps, etc. It is required to use bearings, able not only to resist self-excited vibrations but also to damp the existing vibration for stable operation range extension.

**THE BEARINGS SATISFY THE REQUIREMENTS OF API 617 STANDARD COMPLETELY**



[www.triz-ltd.com](http://www.triz-ltd.com)

Together we are the best!

## Peculiarities and advantages:

- No change of critical rotor speed in casing of the regular bearings replacement;
- Carrying and damping oil layers;
- Damping capacity decreases vibration twice;
- Loose mechanical contact helps to avoid bushings wear and rotor “subsidence” in the rotor support;
- Small rotor procession;
- High load-carrying capacity and vibration velocity;
- Provide guaranteed 6-year equipment runtime;
- Multifunctional scrapers provide individual oil supply, and hot oil removal with the further oil return and they serve as protectors of electroerosion damage.



Scraper for hot  
oil removal from  
the shaft

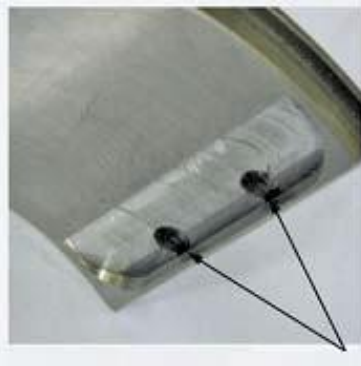

Individual oil  
supply to each  
pad



Oil supply into the  
pocket

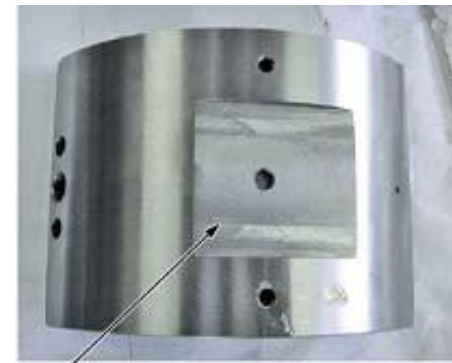

Pocket at the pad  
back



Contact details:  
+442080610941 +447424438725  
Contact Email: [mz@mzccs.co.uk](mailto:mz@mzccs.co.uk) Web site: [www.mzccs.co.uk](http://www.mzccs.co.uk)

[www.triz-ltd.com](http://www.triz-ltd.com)

Together we are the best!



## PIVOT THRUST BEARING (PUR)

Thrust bearings TRIZ® are used for installation instead of the regular bearings of the centrifugal compressors, steam and gas turbines, pumps and the other equipment in view of its capacity to take up more axial force within the dimensions of the regular bearing assembly. They are used in a new machinery manufacturing.

The bearings satisfy the requirements of API 617 standard completely concerning journal bearings.

When installing tilting pad thrust bearings (PU) the load-carrying capacity of the bearing within the standard dimensions increases from 40...100% in conditions of simultaneous lubrication reduction from 30...40%.

Perception of the axial force is equal by all thrust pads. Electroerosive copper application on the bearing pads before babbiting increases strength characteristics of antifriction layer and base interconnection.

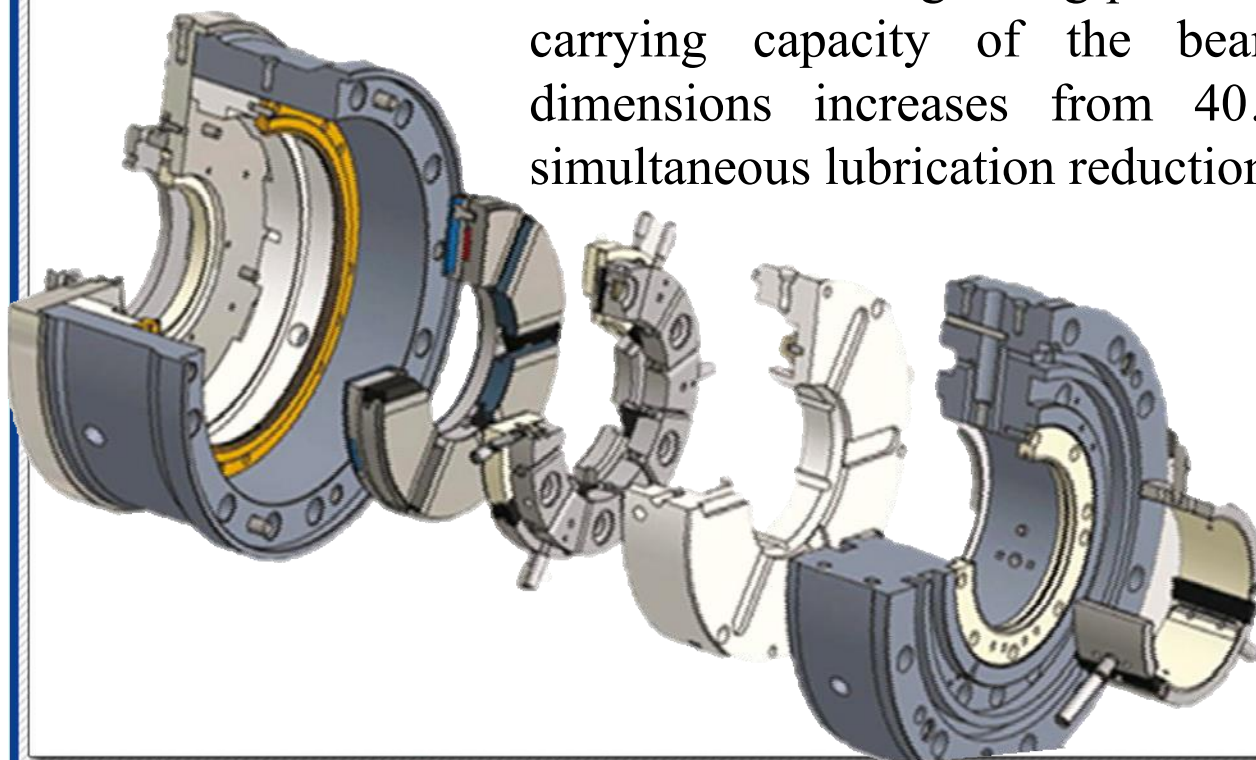

MZ Construction Consumable Supplies LTD

[www.triz-ltd.com](http://www.triz-ltd.com)

Together we are the best!

## Peculiarities and advantages:

- High load-carrying capacity (twice) in comparison with the regular bearings without assembly dimensions increase and lubrication system change;
- Use of the rolling lever system for even perception of the axial load. Irregularity of kingsbury spread  $40^\circ$  decreases to  $6^\circ \dots 8^\circ$ ;
- Low power loss for friction;
- Multifunctional scrapers provide individual oil supply, oil return, hot oil removal and they serve as protectors of electroerosion damage;
- Copper electroerosion alloying increases the babbit bond resistance by 30%.



Contact details:  
+442080610941 +447424438725  
Contact Email: [mz@mzccs.co.uk](mailto:mz@mzccs.co.uk) Web site: [www.mzccs.co.uk](http://www.mzccs.co.uk)

[www.triz-ltd.com](http://www.triz-ltd.com)

Together we are the best!

## Labyrinth seals TRIZ®

Labyrinth seals are used for controlled fluid flow decrease between the rotating and motionless components of the centrifugal compressors, injectors, turbo expanders, steam and gas turbines and other similar equipment. They are used as interstage, intersectional, shaft-end seals and balance piston (dummis) seals.

Seals are designed taking into account the provision of minimal leakages under minimal aerodynamic action on the rotor. It is possible to provide the minimal leakage owing to more efficient seal design or clearance decrease.

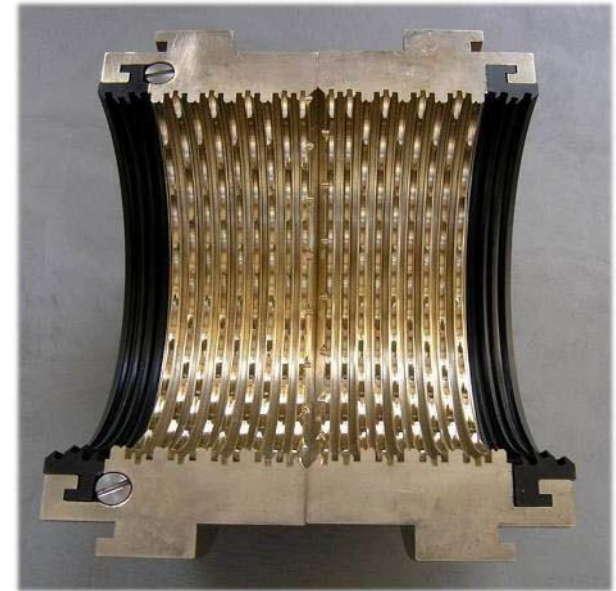

Shaft-end combined seal



Lune seal

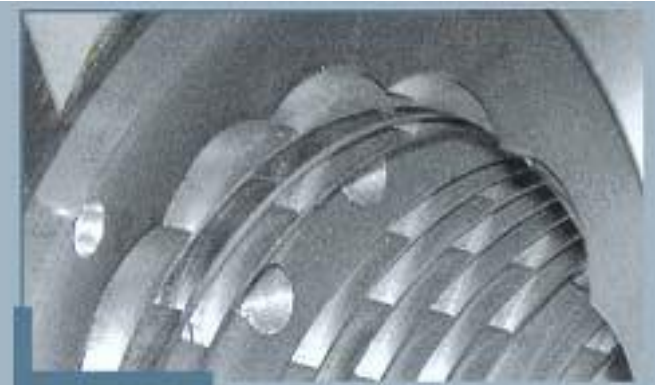

Lunes on the seal surface



Contact details:  
+442080610941 +447424438725  
Contact Email: [mz@mzccs.co.uk](mailto:mz@mzccs.co.uk) Web site: [www.mzccs.co.uk](http://www.mzccs.co.uk)

[www.triz-ltd.com](http://www.triz-ltd.com)

Together we are the best!

One of the actions of self-excited oscillations amplitude drop may serve as the additional damping: for example, the installation of three-pad damping bearings TRIZ<sup>®</sup>. But it will not exclude the cause of vibration. The most efficient action is exclusion or decrease of swirl before the labyrinth seal.

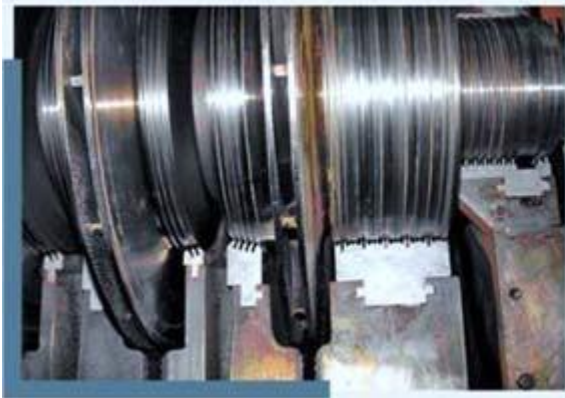

Combined seal of the impeller



Seal made of polymeric material



Dummis seal



Shaft-end seal of the air compressor



Labyrinth seals



Contact details:  
+442080610941 +447424438725  
Contact Email: [mz@mzccs.co.uk](mailto:mz@mzccs.co.uk) Web site: [www.mzccs.co.uk](http://www.mzccs.co.uk)

[www.triz-ltd.com](http://www.triz-ltd.com)

Together we are the best!

## Flexible couplings TRIZ®

For over 20 years TRIZ® has been developing and producing couplings, operating at the pumping and compressor equipment of the leading enterprises of the chemical industry, oil refinery and electric-power industry of Ukraine, Russia and Belarus.

The specialists of TRIZ Ltd have developed software applications package which allows optimizing the couplings according to strength criteria, vibroisolating and compensative characteristics considering the dynamic features of the proper rotor machine. It means that the elaborated design system and calculations of the flexible couplings is directed, firstly, for the highest quality provision and considerations of the individual properties of the unit and coupling operation conditions.



Contact details:  
+442080610941 +447424438725  
Contact Email: [mz@mzecs.co.uk](mailto:mz@mzecs.co.uk) Web site: [www.mzecs.co.uk](http://www.mzecs.co.uk)

[www.triz-ltd.com](http://www.triz-ltd.com)

Together we are the best!

## Characteristics

- the couplings are supplied according to the requirements of API 671 standard;
- they are optimized for maximum continuous rotation torque with safety factor 75%; provide continuous operation in casing of simultaneous exceeding the maximum axial displacement by 25 %, specified by the customer, and maximum shaft misalignment;
- they are optimized according to criteria of strength, vibroisolating properties considering the dynamics of the proper machine.

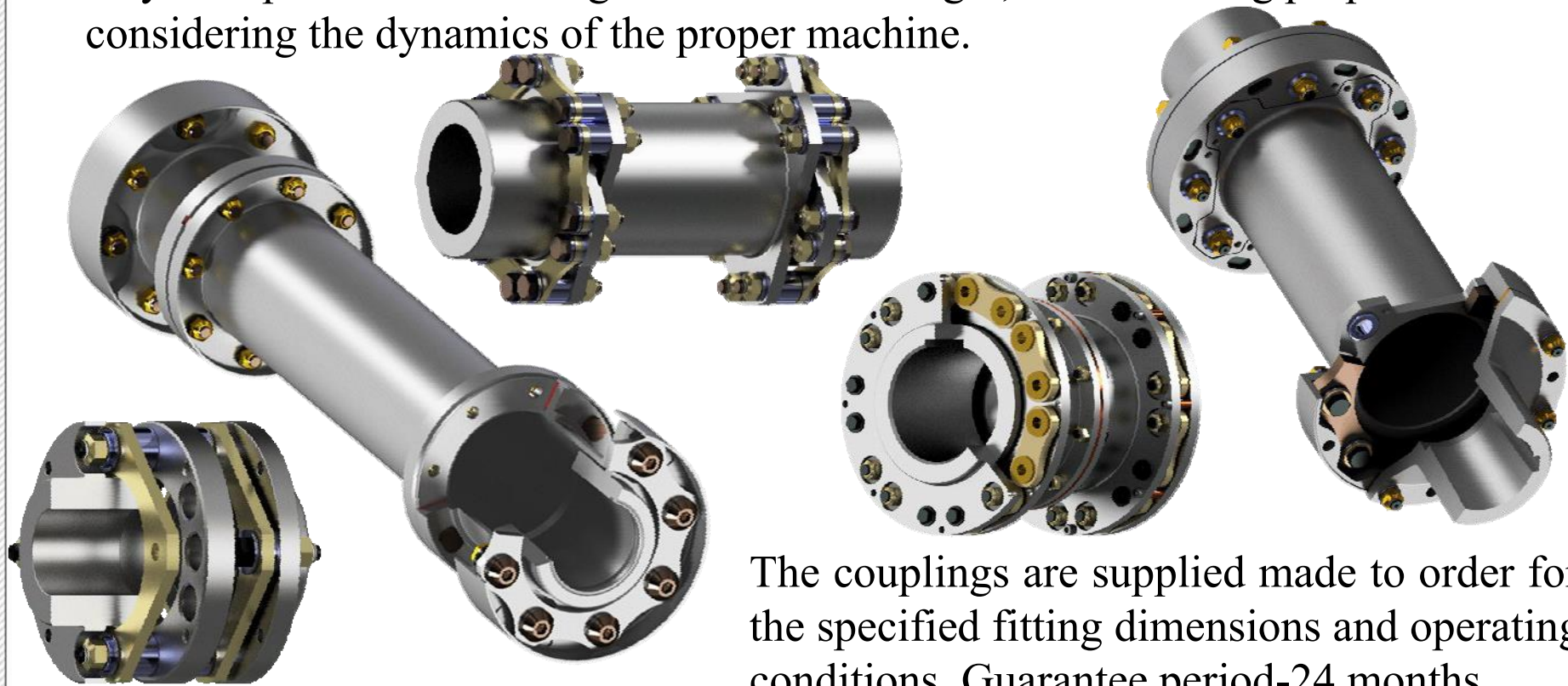

The couplings are supplied made to order for the specified fitting dimensions and operating conditions. Guarantee period-24 months.



Contact details:  
+442080610941 +447424438725  
Contact Email: [mz@mzccs.co.uk](mailto:mz@mzccs.co.uk) Web site: [www.mzccs.co.uk](http://www.mzccs.co.uk)

[www.triz-ltd.com](http://www.triz-ltd.com)

Together we are the best!

## Complex service of the dynamic equipment

Annually TRIZ LTD LLC performs overhauls dynamic equipment in the chemical industries. Participates in various upgrades, takes part in the construction of new production facilities, in terms of dynamic assembly of equipment, working with well-known international companies.

1. Installation of the centrifugal compressor TK-102 (shop Urea 3)

2. Installation of the piston compressor BFV-320 (shop Urea 2)



Contact details;  
+442080610941 +447424438725  
Contact Email: mz@mzccs.co.uk Web site: www.mzccs.co.uk

[www.triz-ltd.com](http://www.triz-ltd.com)

Together we are the best!

## Annual overhauls of dynamic equipment

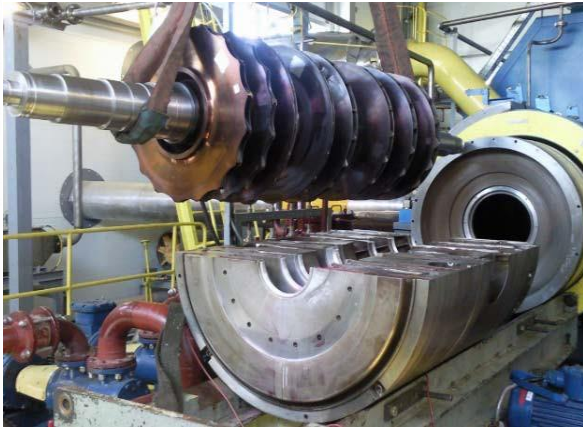

## Restorative repairs after emergency shutdowns



Contact details:  
+442080610941 +447424438725  
Contact Email: [mz@mzccs.co.uk](mailto:mz@mzccs.co.uk) Web site: [www.mzccs.co.uk](http://www.mzccs.co.uk)

[www.triz-ltd.com](http://www.triz-ltd.com)

Together we are the best!



# PRODUCTION AND EQUIPMENT



Contact details:  
+442080610941 +447424438725  
Contact Email: [mz@mzccs.co.uk](mailto:mz@mzccs.co.uk) Web site: [www.mzccs.co.uk](http://www.mzccs.co.uk)

[www.triz-ltd.com](http://www.triz-ltd.com)

Together we are the best!

# PRODUCTION AND EQUIPMENT



Contact details:  
+442080610941 +447424438725  
Contact Email: [mz@mzccs.co.uk](mailto:mz@mzccs.co.uk) Web site: [www.mzccs.co.uk](http://www.mzccs.co.uk)

[www.triz.sumy.ua](http://www.triz.sumy.ua)

Вместе к лучшему!

## VIPER VT30 BLS - super universal turning machining center



## HAAS VF-6 - vertical machining center



## *HAAS VF-6 parts machining*

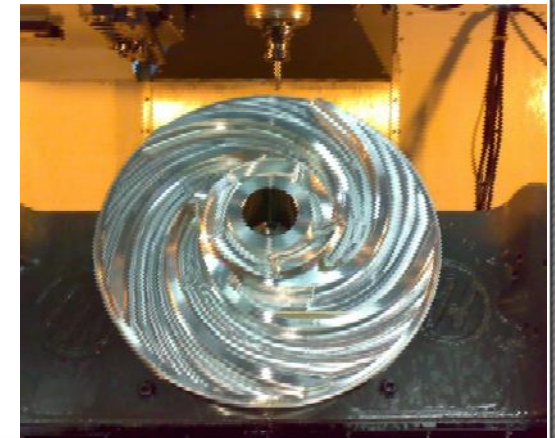
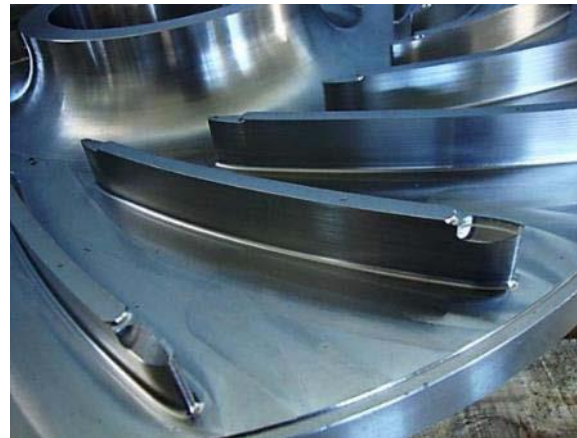

Contact details:  
+442080610941 +447424438725  
Contact Email: [mz@mzccs.co.uk](mailto:mz@mzccs.co.uk) Web site: [www.mzccs.co.uk](http://www.mzccs.co.uk)

[www.triz-ltd.com](http://www.triz-ltd.com)

Together we are the best!

# DMG DMU monoBLOCK



Capstan mod. L600A Hyundai-WIA



Contact details:  
+442080610941 +447424438725  
Contact Email: [mz@mzccs.co.uk](mailto:mz@mzccs.co.uk) Web site: [www.mzccs.co.uk](http://www.mzccs.co.uk)

[www.triz-ltd.com](http://www.triz-ltd.com)

Together we are the best!

# Parts manufactured on the DMU 65FD monoBlock



Contact details:  
+442080610941 +447424438725

Contact Email: [mz@mzccs.co.uk](mailto:mz@mzccs.co.uk) Web site: [www.mzccs.co.uk](http://www.mzccs.co.uk)

[www.triz.sumy.ua](http://www.triz.sumy.ua)

Вместе к лучшему!

## Processing of parts on the five-axis machining

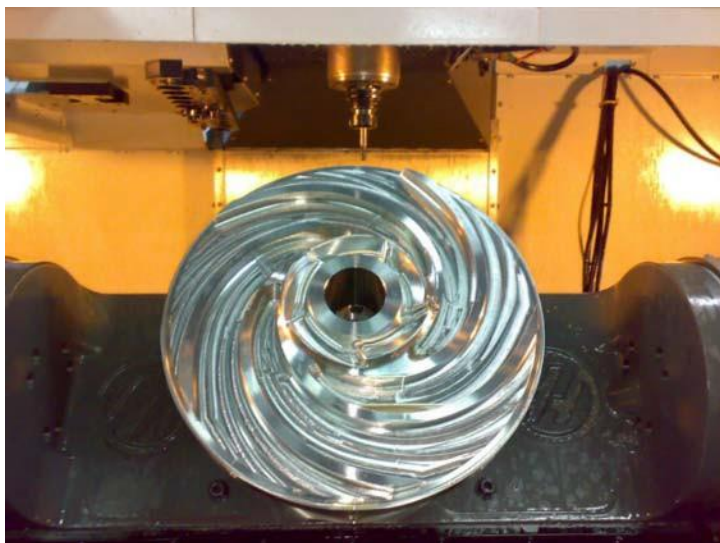

[www.friz.sumy.ua](http://www.friz.sumy.ua)

Вместе к лучшему!

# DOSSAN DBC-110S - horizontal drilling and boring machining center

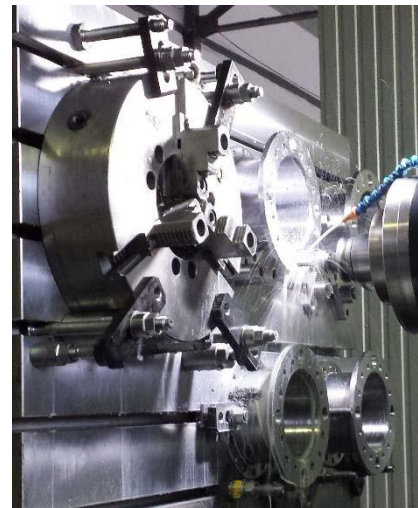

Contact details;  
+442080610941 +447424438725  
Contact Email: [mz@mzccs.co.uk](mailto:mz@mzccs.co.uk) Web site: [www.mzccs.co.uk](http://www.mzccs.co.uk)

[www.triz.sumy.ua](http://www.triz.sumy.ua)

Вместе к лучшему!

# Turning and milling machining center PUMA VTS1620M

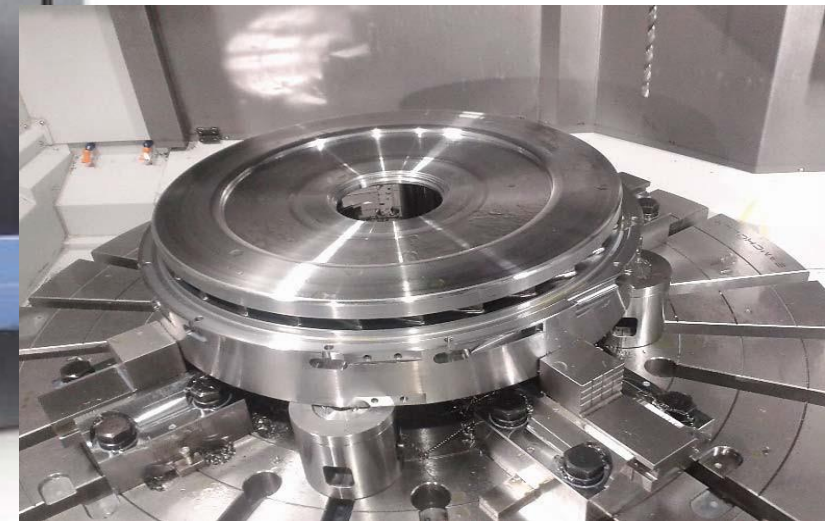

MZ Construction Consumable Supplies LTD

Contact details:

+442080610941 +447424438725

Contact Email: [mz@mzccs.co.uk](mailto:mz@mzccs.co.uk) Web site: [www.mzccs.co.uk](http://www.mzccs.co.uk)

[www.triz.sumy.ua](http://www.triz.sumy.ua)

Вместе к лучшему!



*PUMA VTS1620M turning and milling machining center is used for processing diaphragms and internal casing of dynamic machines.*

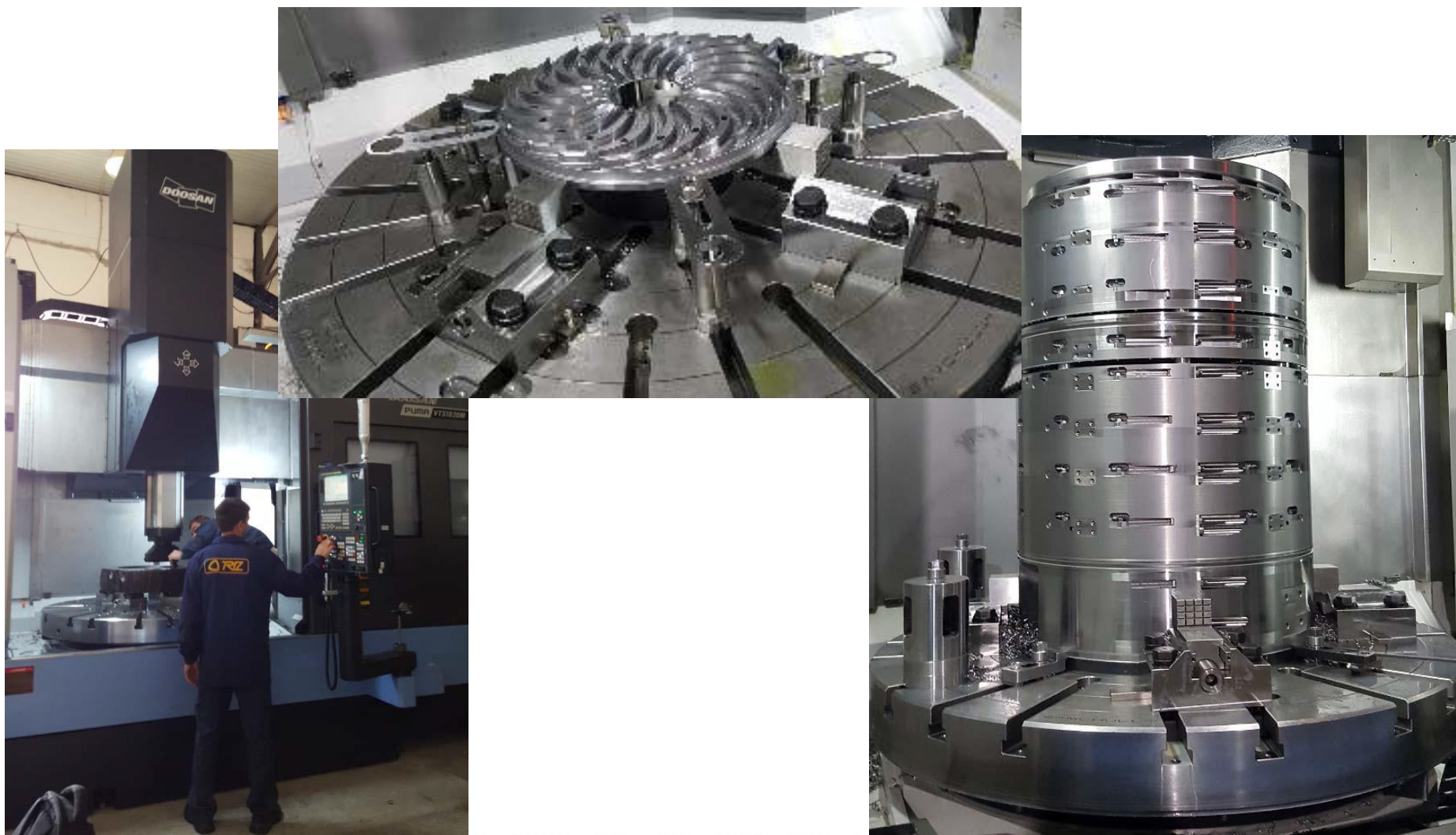

Contact details:  
+442080610941 +447424438725  
Contact Email: [mz@mzecs.co.uk](mailto:mz@mzecs.co.uk) Web site: [www.mzecs.co.uk](http://www.mzecs.co.uk)

[www.triz.sumy.ua](http://www.triz.sumy.ua)

Вместе к лучшему!

*Vertical milling 3-axis machining center  
DOOSAN MYNX 9500*



*Turning machining center  
ALEX-TECH VT-30BLS1000*



MZ Construction Consumable Supplies LTD

Contact details:  
+442080610941 +447424438725  
Contact Email: [mz@mzecs.co.uk](mailto:mz@mzecs.co.uk) Web site: [www.mzecs.co.uk](http://www.mzecs.co.uk)

[www.triz.sumy.ua](http://www.triz.sumy.ua)

Вместе к лучшему!

*Turning machining center DOOSAN PUMA 480L*



*Turning machining center DOOSAN Lynx 220c*



Contact details:  
+442080610941 +447424438725  
Contact Email: [mz@mzccs.co.uk](mailto:mz@mzccs.co.uk) Web site: [www.mzccs.co.uk](http://www.mzccs.co.uk)

[www.triz.sumy.ua](http://www.triz.sumy.ua)

Вместе к лучшему!

*Vertical milling 3-axis machining center  
DOOSAN DNM400II*



*Vertical milling 3-axis machining center  
DOOSAN DNM500II*



Contact details:  
+442080610941 +447424438725  
Contact Email: [mz@mzccs.co.uk](mailto:mz@mzccs.co.uk) Web site: [www.mzccs.co.uk](http://www.mzccs.co.uk)

[www.triz.sumy.ua](http://www.triz.sumy.ua)

Вместе к лучшему!

## *Bogie-type electrical furnace*



## *Shaft furnace with quench tank*



MZ Construction Consumable Supplies LTD

Contact details:  
+442080610941 +447424438725

Contact Email: [mz@mzccs.co.uk](mailto:mz@mzccs.co.uk) Web site: [www.mzccs.co.uk](http://www.mzccs.co.uk)

[www.triz-ltd.com](http://www.triz-ltd.com)

Together we are the best!

# Coordinate Measuring Machine DEA GLOBAL SILVER CLASSIC

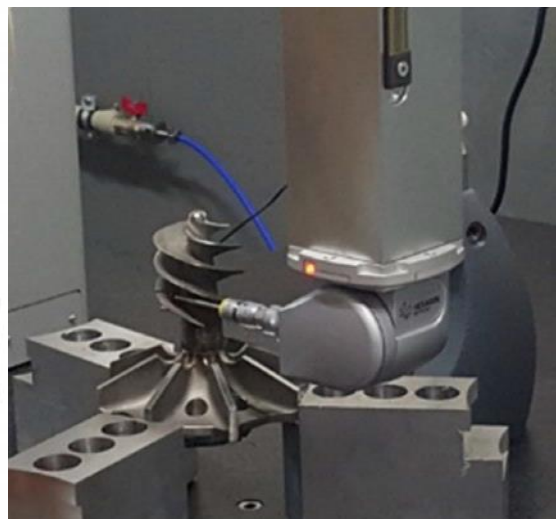

Optical emission spectrometer  
PolySpek Junior



MZ Construction Consumable Supplies LTD

Contact details:

+442080610941 +447424438725

Contact Email: [mz@mzccs.co.uk](mailto:mz@mzccs.co.uk) Web site: [www.mzccs.co.uk](http://www.mzccs.co.uk)

[www.triz.sumy.ua](http://www.triz.sumy.ua)

Вместе к лучшему!

# Thank you for attention!

## Together we are the best!!!



MZ Construction Consumable Supply LTD  
10 North Avenue, Hayes,  
Middlesex, United Kingdom,  
UB3 2JE  
Contact Number:  
+442080610941  
+447424438725

Contact Email: [mz@mzccs.co.uk](mailto:mz@mzccs.co.uk)  
Web site: [www.mzccs.co.uk](http://www.mzccs.co.uk)

<https://youtu.be/sXykUAQAEJc>



MZ Construction Consumable Supplies LTD

Contact details;  
+442080610941 +447424438725  
Contact Email: [mz@mzccs.co.uk](mailto:mz@mzccs.co.uk) Web site: [www.mzccs.co.uk](http://www.mzccs.co.uk)

[www.triz-ltd.com](http://www.triz-ltd.com)

Together we are the best!